

Version
01.00August
2003

Digital HF/VHF/UHF Search Direction Finder R&S DDF[®] 0xA

0.3 MHz to 3000 MHz

- ◆ Wide frequency range from 0.3 (0.09) MHz to 3000 MHz
- ◆ High probability of intercept due to high search DF speed
- ◆ 10 MHz FFT realtime bandwidth
- ◆ Excellent large-signal characteristics
- ◆ High adjacent-channel suppression
- ◆ Algorithms for correlative interferometer, correlation and Watson-Watt as standard
- ◆ Automatic squelch setting (switchable)
- ◆ Direction finding of GSM signals (option)
- ◆ Optimum system compatibility due to
 - efficient data compression
 - fast Ethernet and CORBA (common object request broker architecture)
- ◆ Raw data recording (option)
- ◆ Preclassifier (option)
- ◆ Wide range of antennas from 0.3 MHz to 3000 MHz for stationary and mobile use



ROHDE & SCHWARZ



General

The R&S DDF®0xA family with its extremely high search speed constitutes the current generation of search direction finders. It comprises pure HF (R&S DDF®01A) or VHF/UHF direction finders (R&S DDF®05A) as well as combined HF/UHF/VHF direction finders (R&S DDF®06A).

The FFT realtime bandwidth is 1 MHz (10 MHz optional) in the HF range and 10 MHz in the VHF/UHF range. The frequency range has been extended down to 300 kHz and up to 3000 MHz. All antennas of the R&S ADDx series plus the Antenna Interface R&S GX060 can be used.

Digital DF methods

The type designation R&S DDF®0xA is derived from the term "digital direction finder" to indicate that bearings are determined digitally, i.e. the complex antenna voltages are measured by the high-quality triple DF receiver that acts

like a vector voltmeter and are subsequently digitized. The bearings for any individual signal are evaluated in parallel and independently on the basis of mathematical algorithms. Evaluation can be performed by means of classic direction finding methods such as Watson-Watt or the modern correlative interferometer method.

The correlative interferometer has the following advantages over classic methods:

- ◆ Reduction of DF errors caused by reflections and depolarization
- ◆ Determination of a reliable DF quality criterion for assessing and filtering bearings
- ◆ Possibility of using wide-aperture DF antennas with a minimum number of antenna elements (preferably circular array)

The essential features of the Watson Watt method are:

- ◆ Maximum search/direction finding speed with three-path evaluation (only one measurement step required)

- ◆ Use of antennas with small dimensions in the HF range
- ◆ Easy adaptation of available Adcock antennas (especially in the HF range)

Application

- ◆ Automatic DF and location systems with high probability of intercept
- ◆ Interception and direction finding of frequency hopping and burst signals with automatic evaluation methods
- ◆ Internal data reduction, which limits the results to the truly interesting targets (direction-selective search) and ensures optimal use in automatic interception systems
- ◆ Segmentation of bearings using the Emitter Preclassifier R&S DDF®-CL (option) and delegation of tasks to hand-off receivers
- ◆ In the case of correlation-based evaluation in the HF range also determination of elevation; implementation of single station location (SSL) function
- ◆ Versatile stationary and mobile applications (vehicle, ship, aircraft) by using the most appropriate DF algorithms and different antenna configurations, especially those with wide-aperture characteristics

System configuration

The Search Direction Finders R&S DDF®0xA cover the HF/VHF/UHF frequency range from 0.3 MHz to 1300/3000 MHz with only a few DF antennas.

The type designations of the DF equipment depend on the frequency range (see table on right).

Basically, each direction finder consists of three functional units:

- ◆ DF antenna system
- ◆ DF converter with the integrated three-path DF receiver modules
- ◆ Digital signal processing unit

The DF equipment for the HF range comprises the HF DF Converter R&S EH 110 and the Digital Processing Unit R&S EBD660. For the VHF/UHF range, the VHF/UHF DF Converter R&S ET550 (20 MHz to 3000 MHz) and the Digital Processing Unit R&S EBD660 are used. It is also possible to configure combinations that cover the entire frequency range (0.3 MHz to 3000 MHz).

The algorithms for evaluation according to the Watson-Watt and correlative interferometer method are implemented as standard in the software of the digital signal processing unit. It is thus possible to use any of the evaluation methods depending on the available antenna system and the operational requirements.

The Digital Search Direction Finders R&S DDF®0xA are outfitted with built-in test equipment (BITE) that allows defects down to module level to be located.

Table

Type	Application	Frequency range
R&S DDF®01A	HF	0.3 MHz to 30 MHz
R&S DDF®05A	VHF/UHF	20 MHz to 1300 MHz 20 MHz to 3000 MHz depending on antenna configuration
R&S DDF®06A	HF/VHF/UHF	0.3 MHz to 1300 MHz 0.3 MHz to 3000 MHz depending on antenna configuration

Software can be updated via the service PC (even in remote mode, e.g. via the Internet).

The system configuration is recognized automatically to the greatest possible extent (antenna type, compass, options).

Three DF modes are supported:

Scan mode (fast DF scanning)

In this mode, predefined frequency ranges or frequency lists are searched for activities at maximum speed. The user enters the search range (start and stop frequency, step width) or the list of frequencies to be searched, a lower and, if applicable, an upper evaluation threshold, and the resolution bandwidth. It is also possible to define several search ranges. Two azimuth sectors and (in the HF range) a definition of the elevation range can be entered. In addition, specific frequency bands or frequencies (up to 1000) can be suppressed.

Operational/display concept

The R&S DDF®0xA direction finders do not have any control or display elements. Communication is via an external PC that is connected to the DF system via data and control interfaces (LAN). All the control and display functions can be performed by the standard software (running under Windows2000) supplied with each system.

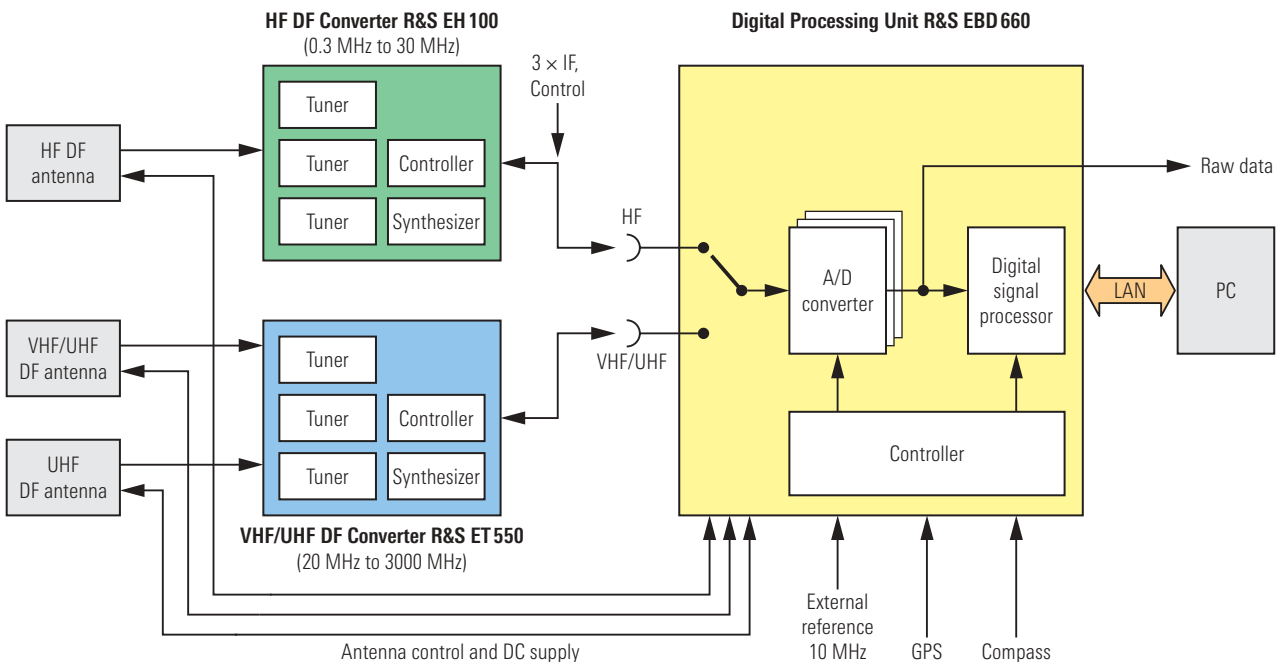

The 1 MHz or 10 MHz realtime analysis window is shifted step by step at high speed in the defined frequency range. All the signals in the window are evaluated in parallel, i.e. simultaneously, by FFT with selectable resolution.

The DF results can be displayed in different ways:

The most simple method is to display the DF values as dots in the "Bearing versus frequency" mode. The "Signal level versus frequency" window underneath shows the current signal occupancy of the selected frequency range or ranges and the signal levels (spectrum display).

Furthermore, the signals can be shown in a waterfall display in their chronological order of arrival. Colour coding (level or azimuth) is another way of differentiating the results. If required, the evaluation threshold (squellch) can automatically be oriented to the noise level.

A large number of tools to be accessed directly via the screen (icons) allows the frequency, azimuth or level subranges to be marked in order to perform measurements or to define zoom ranges.

Values averaged by means of histograms permit stabilized display of individual results.

By clicking a symbol, frequencies of signals that are identified in the spectrum or bearing display and seem to be of interest can be transferred to a hand-off receiver for further examination. It is thus possible to control several receivers.

Results collected during a specific period of time can be stored on the PC's hard disk for later evaluation.

Search DF speed

When specifying the search DF speed of a search DF system, it is always essential to indicate the selectivity conditions under which this speed is attained. In scenarios with high signal activity, especially in the HF range, it is particularly confusing and would distort results if signals that are close to the channel frequency of interest influenced the useful signal.

The selectivity of filters is characterized by the shape factor which refers to the values for 3 dB and 60 dB attenuation, for example. The shape factor of the filters of the R&S DDF[®]0xA direction finders is 3.6 in Scan mode.

Fixed Frequency mode (FFM; operation on a fixed frequency)

In this mode, the FFT window is fixed on the selected center frequency, and an HF range of 20 kHz or 1 MHz and an VHF/UHF range of 100 kHz or 2 MHz are displayed with their spectral occupancy. The DF value allocated to the center frequency is either presented as a polar display or as a histogram with additional waterfall. The signal of the center frequency can be demodulated in this mode. The AF in both analog and digital format is available at the LAN interface for further processing.

Search mode

In this mode, either frequency ranges or frequency lists are searched for activities. Unlike in the Scan mode, the direction finder – before switching over – dwells for a preselectable time on the frequency of any signal that exceeds the evaluation threshold in order to permit short-time monitoring and bearing averaging. The bearings are presented in the same way as in the Fixed Frequency mode.

Options

Master Slave Handover (control of hand-off receivers) R&S RA-MSH

This software package allows hand-off receivers to be controlled via the DF GUI or receiver settings to be transferred to the direction finder in FFM.

LF Extension R&S DDF[®]-LF

This option extends the frequency range down to 9 kHz. It includes a switchover unit (approx. 220 mm × 220 mm × 90 mm) and the required DSP software package.

HF Wide-Band Module R&S DDF[®]A-WB

This option is a DSP firmware package for the R&S DDF[®]01A and the R&S DDF[®]06A. It extends the FFT realtime bandwidth in the HF range up to 2 MHz, 5 MHz or 10 MHz (selectable) and thus provides a higher probability of intercept for short-duration signals.

GSM Interception R&S DDF[®]-GSM

The R&S DDF[®]-GSM enables simultaneous processing of the bearings for all eight timeslots of a GSM telephone channel.

Synchronous Scanning R&S DDF[®]-TS

The internal clock of the direction finders of the R&S DDF[®]0xA/E families can be synchronized by means of a GPS receiver to achieve time-synchronous direction finding of several stations in the search mode and to combine the data obtained for locating. This feature is a prerequisite for detecting frequency hopping transmitters and burst transmissions.

Antennas for Watson-Watt method

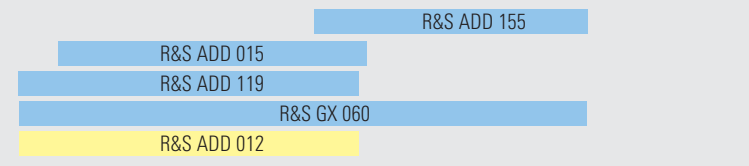

Antennas for correlative interferometer

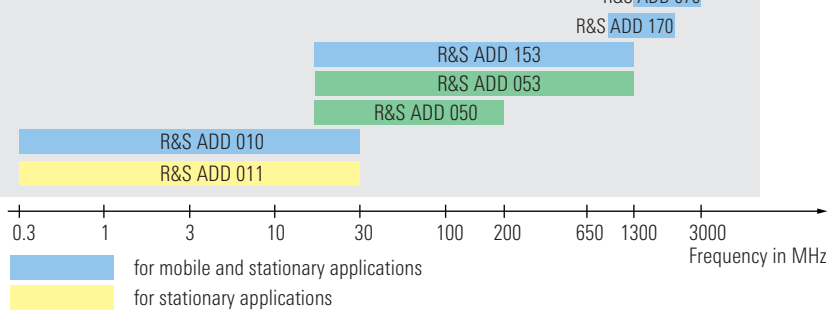

Raw-Data Recording R&S DDF®-DR

In some cases – especially in the presence of short-duration signals – it is desirable to evaluate signals subsequently. In addition to standard storage of all DF data in the background (about 60 s back), the direction finder with the R&S DDF®-DR option is able to store digitized raw data (IF). The data is available for recording via a 1 Gbit/s serial FPDP interface.

Preclassifier R&S DDF®-CL

The R&S DDF®-CL software package runs on the control PC of the direction finder and summarizes the amplitude and bearing spectrum of the R&S DDF®0xA. This makes it possible to derive emissions (segmentation) and calculate parameters such as signal type, center frequency, bandwidth, level and bearing.

DF antennas

The direction finders of the R&S DDF®0xA family operate with the DF Antennas R&S ADDx that are also used for the Direction Finders R&S DDF®0xM, R&S DDF®0xS and R&S DDF®0xE.

The DF Antenna R&S ADD 150 has been modified to provide higher sensitivity in the range from 20 MHz to 100 MHz. It is now called R&S ADD 153.

Frequently, existing DF antennas (especially HF Adcock antennas) from other manufacturers can be used. In these cases, the Antenna Interface R&S GX060 is required. The details must be verified from case to case.

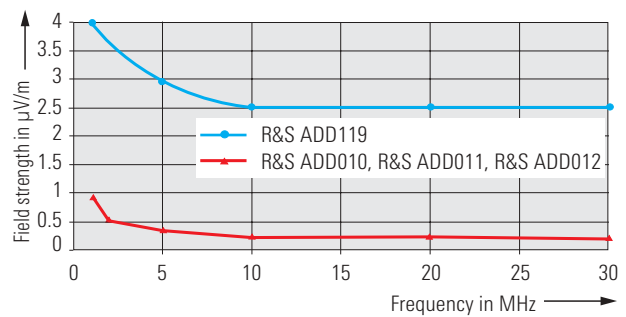

Sensitivity of DF antennas; averaging time 1 s, bearing fluctuation <2°RMS

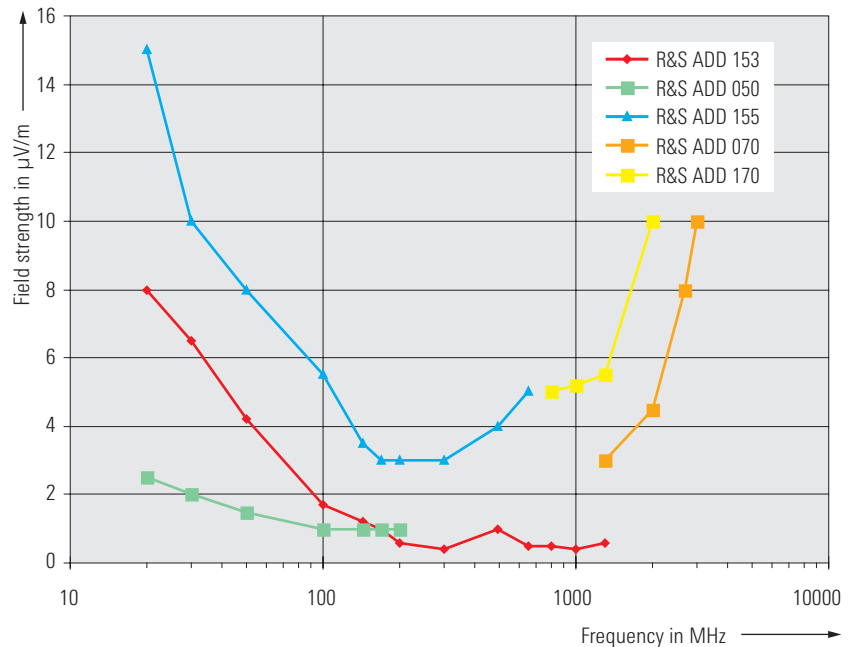

Specifications – HF antennas

Type (Order No.)	R&S ADD119 (4053.6509.02)	R&S ADD010 (4045.0105.03)	R&S ADD011 (4045.0005.13)	R&S ADD012 (4051.1400.03)	R&S ADD012 (4051.1400.13)
Application	mobile, fast scanning for ground waves and sky waves with low elevation angle	semi-mobile and stationary, for signals with elevation angle $\leq 50^\circ$; SSL possible to a limited extent	stationary, for signals with elevation angle $\leq 65^\circ$, SSL possible	semi-mobile and stationary, maximum scanning speed	
Frequency range	(0.3) 1 MHz to 30 MHz, below 1 MHz with limited sensitivity and accuracy	active 9-element circular array of rod antennas	active 9-element circular array of crossed loops	U-Adcock, 1 x 8 elements + center antenna	U-Adcock, 2 x 8 elements + center antenna, switchover at 12 MHz
Antenna type	1 crossed loop and 1 active dipole	correlation	vertical, horizontal, circular	Watson-Watt vertical	
DF method	Watson-Watt	1° RMS			
Polarization	vertical				
DF accuracy ²⁾	2° RMS	typ. 1 $\mu\text{V/m}$ to 0.2 $\mu\text{V/m}$ (2° bearing fluctuation, 1 s averaging time)	1° RMS (1 MHz to 25 MHz)/2° RMS (25 MHz to 30 MHz) when operated in subranges 1 MHz to 12 MHz/12 MHz to 30 MHz	typ. 1 $\mu\text{V/m}$ to 0.2 $\mu\text{V/m}$ (2° bearing fluctuation, 1 s averaging time)	
Sensitivity	typ. 4 $\mu\text{V/m}$ to 2.5 $\mu\text{V/m}$ (2° bearing fluctuation, 1 s averaging time)	160 km/h without ice			
Max. permissible wind speed	200 km/h without ice, 173 km/h with 30 m radial ice deposit				
Operating temperature range	-40°C to +65°C				
Power supply	from DF equipment for antenna cables <10 m, otherwise Power Supply R&S IN061	from power supply integrated as standard			
Dimensions	1100 mm \varnothing x 238 mm	antenna circle: 50 m \varnothing , height of rod antenna: approx. 2 m	antenna circle: 50 m \varnothing , height of crossed loop: 3.4 m incl. tripod	antenna circle: 20 m \varnothing , height of element: 2 m	antenna circle: 20 m \varnothing , height of element: 2 m
Weight	25 kg	single element: 14 kg, network: 22 kg	single element: 33 kg, network: 22 kg	single element: 14 kg, network: 22 kg	

Specifications – VHF/UHF antennas

Type (Order No.)	R&S ADD153 (4063.0003.02)	R&S ADD155 (4040.9004.02)	R&S ADD050 (4041.4005.02)	R&S ADD053 (4062.8800.02)	R&S ADD070 (4043.4003.02/12) ¹⁾	R&S ADD170 (4055.7502.02)
Application	VHF/UHF, mobile and stationary	VHF/UHF, mobile and stationary, maximum search speed	VHF, stationary, enhanced accuracy especially with multipath propagation	VHF/UHF, stationary, combination of R&S ADD153 and R&S ADD050	UHF, stationary, can be mounted below VHF/UHF antennas on same mast	mobile direction finding in GSM bands
Frequency range	20 MHz to 1300 MHz	20 MHz to 500 (650 MHz), above 500 MHz with limited accuracy	20 MHz to 200 MHz	20 MHz to 1300 MHz	1300 MHz to 3000 MHz	800 MHz to 2000 MHz
Antenna type	9 active antenna elements in radome	Adcock, 2 x active 8-element circular arrays in radome	active 9-element circular array	2 x active 9-element circular array	8-element circular array	8-element circular array with center antenna
DF method	correlation	Watson-Watt	correlation			
Polarization	vertical					
DF accuracy ²⁾	2° RMS (20 MHz to 200 MHz) 1° RMS (200 MHz to 1300 MHz)	3° RMS (20 MHz to 50 MHz) 2° RMS (500 MHz to 500 MHz)	1° RMS		2° RMS	
Sensitivity	typ. 8 $\mu\text{V/m}$ to 0.5 $\mu\text{V/m}$ (2° bearing fluctuation, 1 s averaging time)	typ. 15 $\mu\text{V/m}$ to 5 $\mu\text{V/m}$ (2° bearing fluctuation, 1 s averaging time)	typ. 2.5 $\mu\text{V/m}$ to 1 $\mu\text{V/m}$ (2° bearing fluctuation, 1 s averaging time)	wind load on flange: 2078 Nm at 188 km/h without ice, 2495 Nm at 162 km/h with 30 mm ice deposit	typ. 3 $\mu\text{V/m}$ to 10 $\mu\text{V/m}$ (2° bearing fluctuation, 1 s averaging time)	typ. 5 $\mu\text{V/m}$ (0.8 GHz) typ. 10 $\mu\text{V/m}$ (0.2 GHz) (2° bearing fluctuation, 1 s averaging time)
Max. permissible wind speed	200 km/h without ice, 162 km/h with 30 mm radial ice deposit					180 km/h (without ice)
Operating temperature range	-40°C to +65°C					
Power supply	from DF equipment for antenna cables <10 m, otherwise from Power Supply R&S IN061	from Power Supply	Power Supply R&S IN061 required			from DF equipment for antenna cables <10 m, otherwise from Power Supply R&S IN061 ³⁾
Dimensions	1100 mm \varnothing x 238 mm	1100 mm \varnothing x 238	antenna circle: 3 m \varnothing , height: 1 m, with lightning rod: 3.1 m		340 mm \varnothing x 1200 mm (02) 340 mm \varnothing x 492 mm (12)	455 mm \varnothing , height: 365 mm
Weight	30 kg	66 kg	110 kg		90 kg (02), 12 kg (12)	9 kg

¹⁾ Model 12; lightweight model for mobile use.

²⁾ Measurement in reflection-free environment. The RMS error is calculated from the bearings of an evenly distributed azimuth and frequency sample.

³⁾ R&S IN061 required for combination of R&S ADD153 and R&S ADD070.

Specifications

HF range (R&S DDF® 01A and R&S DDF® 06A)

Frequency range	0.3 MHz to 30 MHz
DF method	correlative interferometer, correlation and Watson-Watt
Operation	via GUI on external PC with Windows2000
DF accuracy	instrument error 0.5° RMS
System error (in test field) with DF Antenna R&S ADD010 or R&S ADD011	1° RMS
Display	azimuth/frequency spectrum, polar diagram, histogram, waterfall, realtime IF panoramic display (bandwidth 20 kHz or 1 MHz)
Display resolution	0.1° or 1° (selectable)
DF sensitivity	depending on DF antenna used (see diagram for HF DF antennas, page 5)
Modes of operation	Scan (f-scan, M-scan), Search, Fixed Frequency (FFM)
FFT realtime bandwidth	1 MHz 2/5/10 MHz with R&S DDF®A-WB (option)
Scanning speed (independent of scenario density)	see tables on page 8
Minimum signal duration	see measuring time tables on page 8
Channel spacing	20/10/5/2/1/0.5/0.2/0.1 kHz
Bandwidths (6 dB decrease)	12/6/3/1.2/0.6/0.3/0.12/0.06 kHz
Adjacent channel suppression	80 dB (FFM)
Modes of modulation to be DFed	CW, AM, FM, SSB, FSK, PSK
Modes of reception (demodulation)	CW, AM, FM, SSB
Linearity Second-order intercept Third-order intercept ¹⁾	≥75 dBm ≥32 dBm
Dynamic range (including AGC)	≥120 dB
Intermodulation-free dynamic range In-band Out-of-band	≥75 dB ≥90 dB
Phase noise	<-110 dBc (1 Hz) (1 kHz offset)
Impedance	50 Ω
Frequency stability	1×10 ⁻⁷ at -10°C to +55°C
Frequency setting accuracy	1 Hz
Image frequency rejection	>90 dB, typ. 110 dB
IF rejection	>90 dB, typ. 110 dB

¹⁾ Frequency spacing between intermodulating signals ≥30 kHz.
Higher values are possible if measurements are performed at larger frequency spacing.

VHF/UHF range (R&S DDF® 05A and R&S DDF® 06A)

Frequency range	20 MHz to 3000 MHz
DF method	correlative interferometer, correlation and Watson-Watt
Operation	via GUI on external PC with Windows2000
DF accuracy	instrument error 0.5° RMS
System error (in test field) With DF Antenna R&S ADD053 With DF Antenna R&S ADD070	1° RMS 2° RMS
Polarization	vertical
Display	azimuth/frequency spectrum, polar diagram, histogram, waterfall, realtime IF panoramic display (bandwidth 100 kHz or 2 MHz)
Display resolution	0.1° or 1° (selectable)
DF sensitivity	depending on DF antenna used (see diagram for VHF/UHF antennas on page 5)
Modes of operation	Scan (f-scan, M-scan), Search, Fixed Frequency (FFM)
FFT realtime bandwidth	2/5/10 MHz
Scanning speed (independent of scenario density)	see tables on page 8
Minimum signal duration	see measuring time tables on page 8
Channel spacing	200/100/50/25/20/12.5/8.33/5/2/1 kHz
Bandwidths (1 dB decrease)	120/60/30/15/12/7.5/5/3/1.2/0.6 kHz
Filter characteristics	shape factor (60 dB/3 dB): 3.6 (Scan), 2.5 (FFM)
Adjacent channel suppression	80 dB (FFM), 60 dB (Scan)
Modes of modulation to be DFed	CW, AM, FM, SSB, FSK, PSK
Modes of reception (demodulation)	CW, AM, FM, SSB
Dynamic range (including AGC)	>120 dB
Linearity Second-order intercept Third-order intercept ¹⁾	≥50 dBm ≥18 dBm
Intermodulation-free dynamic range In-band Out-of-band	75 dB 90 dB
Phase noise	<-120 dBc (1 Hz) (10 kHz offset)
Impedance	50 Ω
Frequency stability	1×10 ⁻⁷ at -10°C to +55°C
Image frequency rejection	>90 dB, typ. 110 dB
IF rejection	>90 dB, typ. 110 dB

¹⁾ Frequency spacing between intermodulating signals ≥2.2 MHz.
Higher values are possible if measurements are performed at larger frequency spacing.

Average scanning speed

HF range

Correlation with calculation of elevation

Resolution in kHz	Measuring time in ms	Scanning speed in MHz/s, range >1 MHz	Scanning speed in MHz/s, range ≤1 MHz
10	1.8	250	500
5	2.4	180	270
2	8.2	80	100
1	16.2	50	60

Watson-Watt method

Resolution in kHz	Measuring time in ms	Scanning speed in MHz/s, range >1 MHz	Scanning speed in MHz/s, range ≤1 MHz
10	0.4	380	2,000
5	0.8	320	950
2	1.6	220	420
1	4	150	200

VHF/UHF range

Correlative interferometer

Resolution in kHz	Measuring time in ms	Scanning speed in MHz/s, range >10 MHz	Scanning speed in MHz/s, range ≤10 MHz
100	0.4	6000	20000
50	0.5	5500	15000
25	0.8	4800	8000
20	1	4500	7000
12.5	1.5	3500	5500
10	1.76	3000	5000
8.33	2.08	2800	4400

The specified scanning speeds are independent of the channel occupancy.



More information at
www.rohde-schwarz.com
(search term: Digital Search Direction
Finder DDF0xA)

General data

(valid for R&S DDF®01A, R&S DDF®05A and R&S DDF®06A)

	R&S EBD660	R&S EH 110	R&S ET550
Operating temperature range	−10 °C to +55 °C acc. to DIN EN 60068-2-1, DIN EN 60068-2-2, MIL-STD-810E method 501.3/502.3		
Storage temperature range	−40 °C to +71 °C acc. to DIN EN 60068-2-1, DIN EN 60068-2-2, MIL-STD-810E method 501.3/502.3		
Humidity/damp heat	max. 80% cycl. test at 25 °C/40 °C acc. to DIN EN 60068-2-30 max. 95% rel. humidity, without condensation, acc. to MIL-STD-810E method 507.3, without cyclic condensation		
Mechanical resistance/shock	30 g, 1 ms semi-sinewave acc. to DIN EN 60068-2-27 40 g shock spectrum, 45 Hz to 2000 Hz acc. to MIL-STD-810E, method 516.4		
Vibration Sinusoidal Random	5 Hz to 55 Hz, max. 2 g, 55 Hz to 150 Hz, 0.5 g const., 12 min/(3)axis acc. to DIN EN 60068-2-5, MIL-T 28800D class 5 10 Hz to 500 Hz, 1.9 g (rms), 30 min/(3)axis acc. to DIN EN 60068-2-64		
EMC	30 MHz to 1000 MHz, 30/37 dBµV/m, field strength (emission) acc to IEC/CISPR 22 0.15 MHz to 30 MHz class B interference voltage on power lines acc. to EN 50081-1, EN 61000-6-2 0 Hz to 2 kHz interference current on power lines acc. to IEC 6100-3-2 ±8 kV/±4 kV static discharge acc. to IEC 6100-4-2 80 MHz to 100 MHz, 10 V/m field strength (immunity) acc. to IEC 6100-4-3 ±2 kV/±1 kV transient burst at mains/signal connection (immunity) acc. to IEC 6100-4-4 ±2 kV/±1 kV symm. burst voltage (immunity) acc. to IEC 6100-4-5 0.15 MHz to 80 MHz, 10 V unmod./mod. 80% AM (1 kHz) on lines acc. to IEC 6100-4-6 50 Hz, 30 A/m, magnetic field strength (immunity) acc. to IEC 6100-4-8 10 ms/30%, 100 ms/60% voltage reduction, 5 s voltage interruption on power lines acc. to IEC 6100-4-11		
Power supply Electrical safety (acc. to EN 61010, VDE 0411)	100 V to 230 V AC, +10%/−12%, 47 Hz to 63 Hz max. 350 VA, typ. 300 VA	max. 150 VA, typ. 120 VA	max. 200 VA, typ. 180 VA
Dimensions (W × H × D)	436 mm × 192 mm × 460 mm (19" × 4 HU)		
Weight	approx. 15 kg	approx. 16 kg	approx. 18 kg

Ordering information

Designation	Type	Order No.
Digital HF Search Direction Finder	R&S DDF®01A	4059.9100.02
Digital VHF/UHF Search Direction Finder	R&S DDF®05A	4059.9200.02
Digital HF/VHF/UHF Search Direction Finder	R&S DDF®06A	4059.9300.02
Antennas	R&S ADDx	see tables on page 6
Master Slave Handover	R&S RA-MSH	3020.9690.02
LF Extension	R&S DDF®-LF	4060.0348.02
HF Wide-Band Module	R&S DDF®A-WB	4060.0248.02
GSM Interception	R&S DDF®-GSM	4059.9951.02
Synchronous Scanning	R&S DDF®-TS	4060.0290.02
Raw-Data Recording	R&S DDF®-DR	4060.0390.02
Preclassifier	R&S DDF®-CL	4059.9900.02



ROHDE&SCHWARZ

Rohde&Schwarz GmbH&Co. KG · Mühlendorfstraße 15 · 81671 München · Germany

P.O.B. 801469 · 81614 München · Germany · Telephone +49 89 4129-0 · Fax +49 89 4129-13247 · www.rohde-schwarz.com

R&S® is a registered trademark of Rohde&Schwarz GmbH&Co. KG · Trade names are trademarks of the owners
PD 0758.0374.32 · Digital HF/VHF/UHF Search Direction Finder R&S DDF 0xA · Version 01.00 · August 2003 · Data without tolerance limits is not binding · Subject to change

Printed in Germany (B1 sk)